

Manometer-Gauge-Valve Type MA01



Image similar

description:

Manometer gauge valve to connect a measuring instrument. Suitable for liquids, gas and steam.

features:

- suitable for liquids, gas and steam
- maintenance free
- DIN 16270 or DIN 16271
- connection G1/2"
- with hand wheel
- for connection to the manometer please use a sealing according to DIN 16258

connection:

G1/2" inch

temperature:

-10°C up to 200°C – depending on design

pressure:

up to 400 bar– depending on design

design:

MA0100 male thread x sleeve

MA0101 sleeve x sleeve

MA0102 male thread x adapter for instrument holder with nut adjustable

MA0103 male thread x sleeve x test connector M20 x 1,5

MA0104 sleeve x sleeve x test connector M20 x 1,5

MA0105 male thread x adapter for instrument holder with nut adjustable x test connector M20 x 1,5

MA0106 male thread x sleeve x test flange 60 x 25 mm

nominal pressure:

PN250 or PN400 depending on design

material:

brass, full brass, steel 1.0460, stainless steel 1.4571

sealing:

steel = graphite / brass und stainless steel = PTFE

standard:

DIN 16270 or DIN 16271

MA0100 Manometer gauge valve DIN 16270, male thread x sleeve

type	A	DIN	PN/bar	°C	L1/mm	L2/mm	F/mm	S1	material	sealing
MA01	G1/2	16270 A	250	120	100	100	63	27	brass	PTFE
MA01	G1/2	16270 A	250	120	100	100	63	27	full brass	PTFE
MA01	G1/2	16270 A	400	120	100	94	63	27	steel 1.0460	Graphite
MA01	G1/2	16270 A	400	200	100	94	63	27	stainless steel 1.4571	PTFE

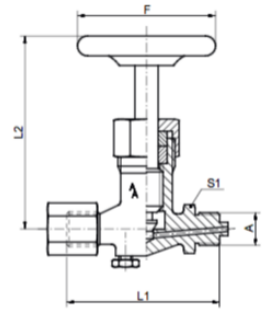

MA0101 Manometer gauge valve DIN 16270, sleeve x sleeve

type	A	DIN	PN/bar	°C	L1/mm	L2/mm	F/mm	S1	material	sealing
MA01	G1/2	16270	250	120	100	100	63	27	brass	PTFE
MA01	G1/2	16270	250	120	100	100	63	27	full brass	PTFE
MA01	G1/2	16270	400	120	100	94	63	27	steel 1.0460	Graphite
MA01	G1/2	16270	400	200	100	94	63	27	stainless steel 1.4571	PTFE

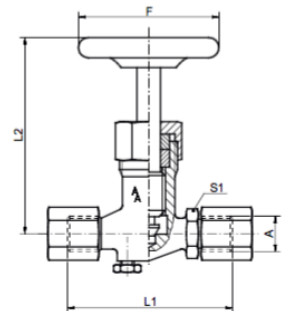

MA0102 Manometer gauge valve DIN 16270, male thread x Adapter for instrument holder with nut adjustable

type	A	DIN	PN/bar	°C	L1/mm	L2/mm	F/mm	S1	material	sealing
MA01	G1/2	16270 B	250	120	125	100	63	27	full brass	PTFE
MA01	G1/2	16270 B	400	120	120	94	63	27	steel 1.0460	Graphite
MA01	G1/2	16270 B	400	200	120	94	63	27	Stainless steel 1.4571	PTFE

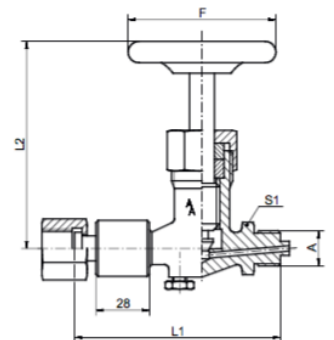

MA0103 Manometer gauge valve DIN 16271, male thread x sleeve x test connector M20 x 1,5

type	A	DIN	PN/bar	°C	L1/mm	L2/mm	F/mm	S1	material	sealing
MA01	G1/2	16271 A	250	120	100	100	63	27	brass	PTFE
MA01	G1/2	16271 A	250	120	100	100	63	27	full brass	PTFE
MA01	G1/2	16271 A	400	120	100	94	63	27	steel 1.0460	Graphite
MA01	G1/2	16271 A	400	200	100	94	63	27	Stainless steel 1.4571	PTFE

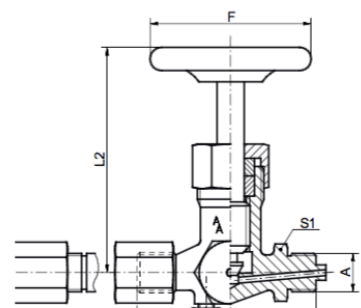

MA0104 Manometer gauge valve DIN 16271, sleeve x sleeve x test connector M20 x 1,5

type	A	DIN	PN/bar	°C	L1/mm	L2/mm	F/mm	S1	material	sealing
MA01	G1/2	16271 A	250	120	100	100	63	27	brass	PTFE
MA01	G1/2	16271 A	400	120	100	94	63	27	steel 1.0460	Graphite
MA01	G1/2	16271 A	400	200	100	94	63	27	stainless steel 1.4571	PTFE

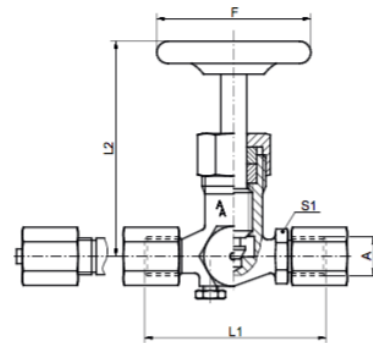

MA0105 Manometer gauge valve DIN 16271, male thread x Adapter for instrument holder with nut adjustable x test connector M20 x 1,5

type	A	DIN	PN/bar	°C	L1/mm	L2/mm	F/mm	S1	material	sealing
MA01	G1/2	16271 B	250	120	125	100	63	27	brass	PTFE
MA01	G1/2	16271 B	400	120	122	94	63	27	steel 1.0460	Graphite
MA01	G1/2	16271 B	400	200	122	94	63	27	Stainless steel 1.4571	PTFE

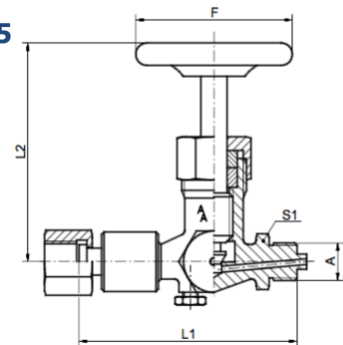

MA0106 Manometer gauge valve DIN 16271, male thread x sleeve x test flange 60 x 25 mm

type	A	DIN	PN/bar	°C	L1/mm	L2/mm	F/mm	S1	material	sealing
MA01	G1/2	16271	250	120	100	100	63	27	brass	PTFE
MA01	G1/2	16271	250	120	100	100	63	27	full brass	PTFE
MA01	G1/2	16271	400	120	100	94	63	27	steel 1.0460	Graphite
MA01	G1/2	16271	400	200	100	94	63	27	Stainless steel 1.4571	PTFE

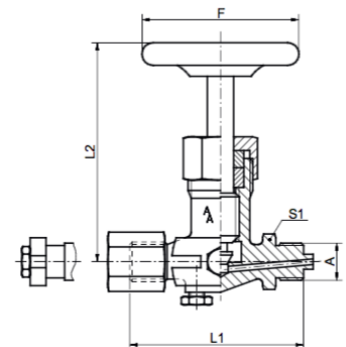

Article number:

type	design	material	connection
MA01	00 - male thread x sleeve 01 - sleeve x sleeve 02 - male thread x adapter for instrument holder with nut adjustable 03 - male thread x sleeve x test connector M20 x 1,5 04 - sleeve x sleeve x test connector M20 x 1,5 05 - male thread x adapter for instrument holder with nut adjustable x test connector M20 x 1,5 06 - male thread x sleeve x test flange 60 x 25 mm	00 – brass 01 – full brass 02 – steel 1.0460 03 – stainless steel 1.4571	03 – 1/2"

Example no. MA01060203

MA01 | 06

| 02

| 03

Article no. MA01060203

Manometer gauge valve

design: male thread x sleeve x test flange 60 x 25 mm

material: steel 1.0460

connection: G1/2"

Image similar, subject change without notice.